



FRONT DRIVE KIT OPERATORS MANUAL

SECTION 1

Installation

1.1 Front PTO Shaft Installation. See the illustration.

1. Remove the caps in the front axle.
2. Clean the hole and snap ring grooves.
3. Put a snap ring in the rear snap ring groove.
4. Slide a bearing onto the front PTO shaft from the end which is farthest from the shoulder (2.8").
5. Start the bearing into the front of the axle and tap the front PTO shaft with a soft hammer until the bearing is against the snap ring.
6. Slide the other bearing onto the front of the front PTO shaft and push it into the axle so that the snap ring can be installed in the axle. Be careful not to damage the bearing seal.
7. Install the front snap ring in the axle.

1.2 Front Attachment Bracket Installation

Orientate the front attachment brackets so that the latch is on the inside. See the illustration. Retain with three 1/2" bolts and two 1/2" locknuts each.

1.3 Drive Installation

1. Orientate the drive as shown in the illustration.
2. Put a film of multi-purpose grease on the shaft and slide it into the tube.
3. Oil the locking collar and pins at each end of the drive.
4. Pull the locking collar on the tube end toward the drive and slide it on the transmission PTO shaft. Release the locking collar and work the drive back and forth to make sure that the pins have locked into the groove in the PTO shaft.
5. Similarly connect the front of the drive to the rear of the front PTO shaft.

1.4 Push Rod Guide Installation

1. Read the tractor and attachment operator's manuals.
2. Put the push rod guide in the hole in the tractor lift as instructed in the attachment operator's manual.
3. Retain the push rod guide with a flat washer and hair pin cotter.
4. If the kit is installed on a long frame tractor, put the 4" (10.2 cm) spacer on the push rod guide before sliding it into the push rod.
5. If the attachment touches the front of the tractor front tires, put the washer on the push rod guide.

SECTION 2

Illustrated Parts and Parts List

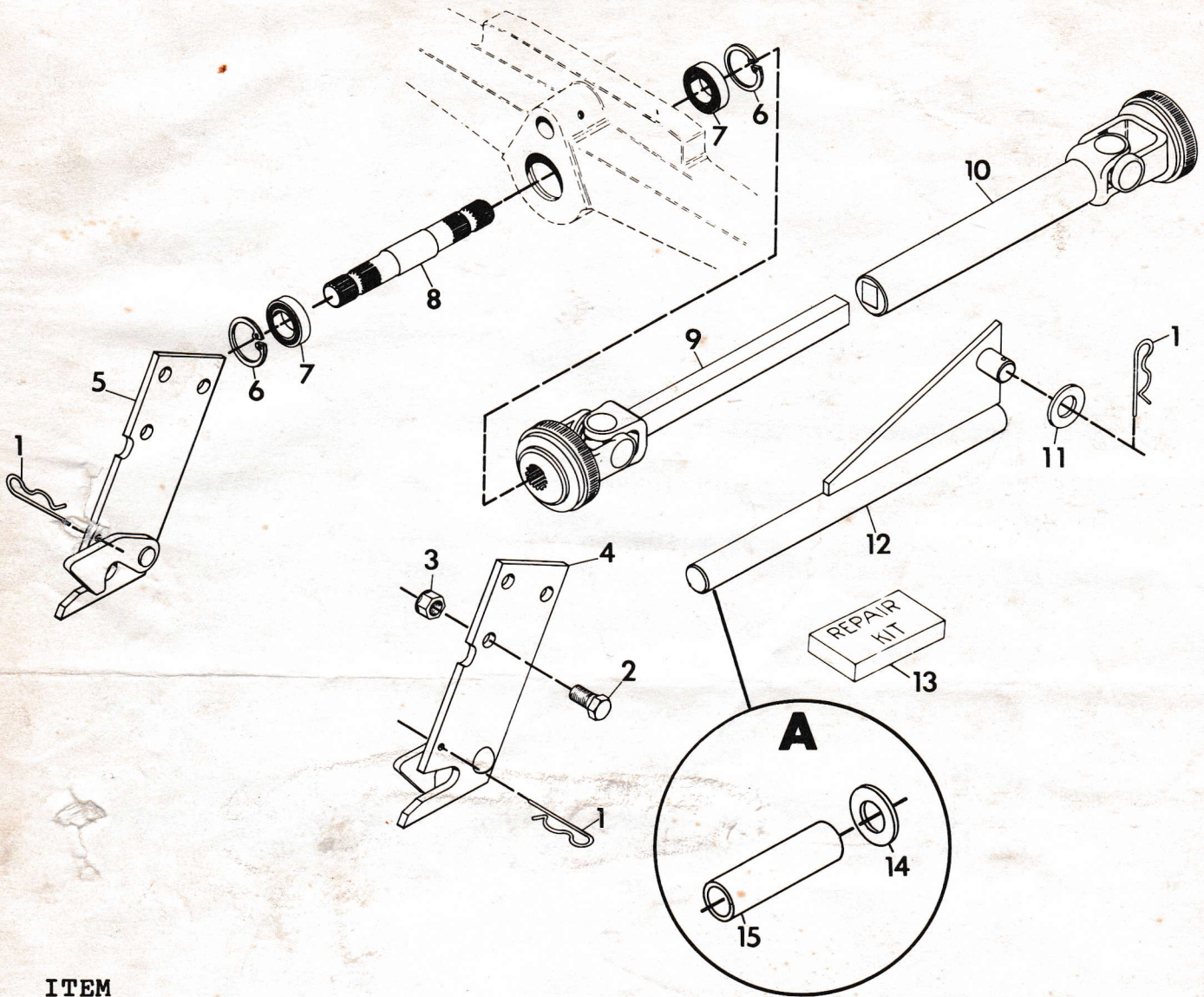

ITEM NO.	PART NO.	QTY.	DESCRIPTION
1	10405	3	Pin, Hair
2	180173	6	Bolt, Hex 1/2-13x1
3	120378	4	Nut, Hex 1/2-13
4	40324	1	Assembly, Attachment Bracket L.H.
5	40325	1	Assembly, Attachment Bracket R.H.
6	19073	2	Ring, Retaining 2.062 Bore
7	19072	2	Bearing, Ball .984x2.047x.590
8	18654	1	Shaft, Frt PTO
9	15802	1	Joint, U, Male End
10	18653	1	Shaft, Frt PTO Prop.
11	131017	1	Washer, Flat .812x1.496x.134
12	11396	1	Guide, Push Rod Weldment
13	24560	1	Kit, Repair U-Joint (Neapco)
14	131019	1	Washer, Flat 1.062x2.000x.134
15	31301	1	Spacer

NOTE: Circle "A" pertains to 8000 Series tractor that has the long frame.